



The Series PK-200, a New  
**PHOTOELECTRIC  
KEYBOARD**

for O.E.M. and User Applications.

**Format and Function Flexibility:**

to meet specific Data Handling System requirements.

**Universal Coding:**

custom coding with simultaneous outputs of up to 14 bits.

**Photoelectric Technique:**

eliminates contact bounce; minimizes RFI/EMI.

**THE INVAC SERIES PK-200 PHOTOELECTRIC KEYBOARD.**

This keyboard converts operator alphanumeric input information into coded electrical signals which serve as input to a wide variety of data handling devices. It is ideally suited for applications such as data display consoles, computer programming, input to tape punches in paper tape preparation and as an inquiry device for data processing and information retrieval systems.

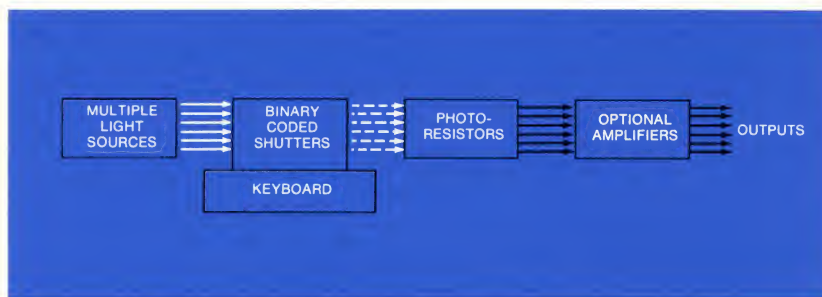

**THE INVAC PHOTOELECTRIC TECHNIQUE.**

When depressed, the keys on the Series PK-200 Keyboard move binary coded shutters to interrupt light beams. The abrupt difference in light intensity reaching one or more photo-resistors produces very large changes in their individual resistances. These ohmic changes are available as direct outputs or may be converted by amplifiers to corresponding voltage level changes. The amplifiers have very low output impedances and may be connected to practically any other data system device. Other electronic circuits perform a "strobe" function to prevent incorrect data from entering the system. A mechanical interlock prevents depressing more than one key at a time.

The standard keyboard is practically "fail-safe" because the channel lamps are operated in series; failure of any lamp produces an easily sensed continuous output on all channels. Possibility of failure is reduced by the use of conservatively operated long-life lamps and the use of highly-reliable all solid-state electronics.

**Flexibility in Format and Function** is the prime feature of the Invac Series PK-200. Almost any customer requirement can be accommodated rapidly and at nominal cost. Therefore, this keyboard series is particularly well suited to the O.E.M. market. A partial list of options follows:

- Any number of keys from 10 to 75.
- Standard diagonal and in-line combination of key layout.
- Four or five bank keyboards.
- Function switches and/or indicator lamps can be added at the sides or in the "hood" on top.
- Special case designs. Keyboard can be supplied without case.
- Standard and special machine functions can be accommodated.
- Any code can be provided.
- Choice of eight standard logic levels.
- MIL requirements for environment and RFI/EMI.
- Customized operating force for keys.
- Remote keyboard lock.
- All-key mechanical storage latch, released by "reset" signal.
- Selective blocking of unused code keys.

**Other Features:** Keys on 3/4" centers, with easily replaced custom engraved keytops. Choice of four keytop colors: white, light blue, dark blue and gray.

# PHYSICAL CHARACTERISTICS

# SPECIFICATIONS

## DIMENSIONS

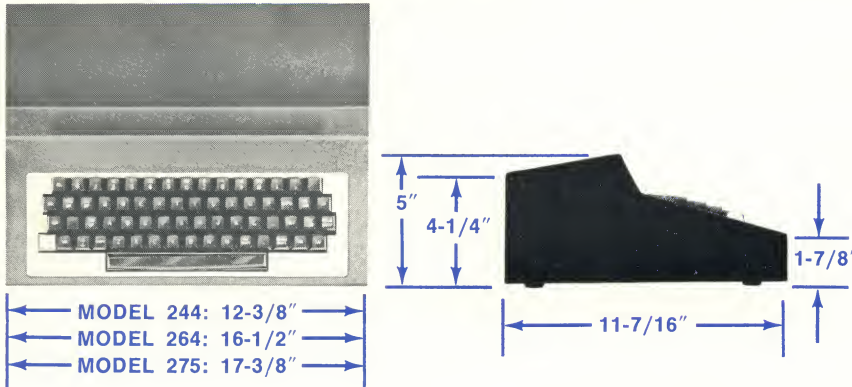

## WEIGHT (pounds)

Model	Operating	Shipping
PK-244	15	20
PK-264	17	22
PK-275	19	24

Operating Temperature Range: 0°C. to +50°C.

## A RECOGNIZED LEADER IN KEYBOARD DESIGN

Extensive custom design experience, as the originator of the photoelectric keyboard (U.S. Patent Number 3,092,310), has permitted INVAC to anticipate and make provisions for the needs of a broad range of data handling systems in the basic modular design of this new Series PK-200. Mechanical logic and interlocks are used wherever possible to simplify interface design and increase reliability. Rugged, time-proven, all-metal typewriter design and construction are used throughout.

Another example of INVAC design "know-how" is in the "touch" of the keyboard. Since keyboard operators are normally regular users of conventional electric typewriters, INVAC has incorporated standard typewriter layout and "feel" in the Series PK 200 Keyboard. The inherent advantages in improved speed and reduced transmission error are the important result.

This keyboard is reliable and silent because no motors or clutches are used. Long maintenance-free operation is assured for these compact keyboards since the power dissipation is low and practically no heat is generated inside the case.



26 Fox Road, Waltham, Massachusetts 02154  
Tel. (617) 899-2380

TAPE PUNCHES • READERS AND HANDLERS  
I/O TYPEWRITERS • PRINTERS AND SYSTEMS

## KEYBOARD

Number of alphanumeric keys: 10 to 75

### Standard Models and Number of Keys

PK-244	44
PK-264	64
PK-275	75

**Oversize keys:** provided for special functions and selected machine functions.

**Key interlock:** prevents depression of more than one character key at one time.

**Output code:** any binary combination up to 10 bits; up to 14 bits on special order.

**Operating life expectancy:**  
keys: 100,000,000 operations, minimum  
lamps: 20,000 hours, minimum

**Peak entry rate:** 20 characters per second, continuous.

**Key force level:** 1 to 2 ounces or greater.

**Key spacing:** 3/4 inch centers.

**Keytop colors:** white, light blue, dark blue or gray.

**Keytop marking:** up to 15 characters (in 3 rows of 5 characters) may be engraved and paint-filled on each keytop.

**Key format:** diagonal is standard; in-line or combinations of in-line and diagonal can be provided.

**Optional keyboard lock:** provided by a remotely actuated solenoid (26 volts at 1.0 amp.).

**Optional automatic selective blocking of unused code keys.**

## ELECTRICAL

**Basic Models with Direct Photoresistor Outputs** (not including electronic amplifiers):

### Input Power (dc only):

Lamp Power:

Series Lamp Connection: 20 v, (min) at 350 milliamperes.

Parallel Lamp Connection: 2 v, ±0.1 v, at 3.5 amperes.

Note: Maximum photoresistor bias is 60 volts and photoresistor dissipation must not exceed 75 milliwatts, each, at 25°C.

### Logic Output (data and strobe)

Logical ONE (key depressed)  
200,000 ohms (min)

Logical ZERO (key at rest)  
2,000 ohms (max)

**Models with Electronic Amplifier Outputs:**

### Input Power (dc only):

Lamp Power:

Series Lamp Connection: 20 v, (min) at 350 milliamperes.

Parallel Lamp Connection: 2 v, ±0.1 v, at 3.5 amperes.

Amplifier Power Requirements: see chart, below.

### Logic Output (data and strobe) and Amplifier Input Power

Option	LOGIC LEVELS				INPUT POWER (dc only)	
	ONE (key depressed)		ZERO (key at rest)		Voltage (±10%)	Current (max)
1	- .2±.2	7 mA	-12	1800 ohms	-12	150 mA
2	-12	1800 ohms	- .2±.2	7 mA	+6	30 mA
3	- .2±.2	7 mA	-6	1000 ohms	-6	150 mA
4	-6	1000 ohms	- .2±.2	7 mA	+6	30 mA
5	+ .2±.2	7 mA	+12	1800 ohms	+12	150 mA
6	+12	1800 ohms	+ .2±.2	7 mA	-6	30 mA
7*	+ .2±.2	7 mA	+4to+6	1000 ohms	+4to+6	150 mA
8*	+4to+6	1000 ohms	+ .2±.2	7 mA	-6	30 mA

\*Specify exact level required.

Strobe Signal: 20 millisecond pulse occurring after data channels have stabilized.

Specifications are subject to change without notice.



26 FOX ROAD, BEAR HILL INDUSTRIAL PARK, WALTHAM 54, MASSACHUSETTS — Tel. 899-2380

PRELIMINARY DATA SHEET NO. S-8  
APRIL 22, 1966

PRODUCT: PHOTOELECTRIC KEYBOARD, MODEL SERIES PK-200

DESCRIPTION:

The basic photoelectric keyboard consists of the following major assemblies:

- a. Light source assembly with up to 10 light channels.
- b. Photocell assembly containing up to eight data channel photocells, one strobe channel photocell, and one spare channel.
- c. Keylever/shutter assemblies.
- d. Mechanical ball interlock assembly.

The keyboard can be supplied with various key layouts incorporating from 10 to 75 keys, with or without amplifier and strobe delay electronics, and with a wide variety of special optional function switches. Although designed with a standard case, special case designs can be supplied to suit individual customer requirements.

OPERATION:

A key depression causes a binary coded shutter to interrupt light beams in the light channels. This results in impedance changes at the photocell outputs corresponding to the code of the shutter. The photocell outputs may go directly to external amplifiers or may be converted into logical output voltages compatible with computer logic by an amplifier stage incorporated in the keyboard. A strobe pulse is generated by the strobe channel and is electronically delayed to insure that all data outputs are present. A mechanical interlock allows only one key to be depressed at a time, but allows "rolling" key action and rapid typing speeds. A remotely operated keyboard lock can be provided.

INPUT REQUIREMENTS:

- 26 VDC, 0.5 amperes max.
- 12 VDC, 150 ma. max.
- +6 VDC, 20 ma. max.

OUTPUT CHARACTERISTICS:

Photocells: Logical ONE - 200,000 ohms min.  
 Logical ZERO - 2000 ohms max.

Amplifiers\*: Logical ONE - 0 VDC  
 Logical ZERO - 12 VDC

\* Standard logic levels. Other levels can be provided.

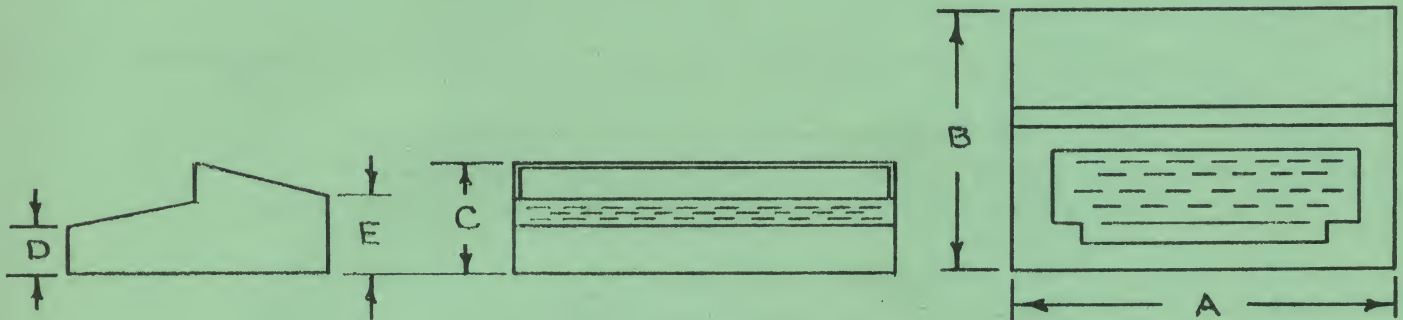

Model	Number of Keys	Dimensions (inches)				
		A	B	C	D	E
244	44	12-3/8	11-7/16	5	1-7/8	4-1/4
264	64	16-1/2	11-7/16	5	1-7/8	4-1/4
275	75	17-3/8	11-7/16	5	1-7/8	4-1/4

PRICES\*:

Item	Description	List Price
Model 244	Basic 44 key keyboard, less electronics	\$475.00
Model 264	Basic 64 key keyboard, less electronics	\$565.00
Model 275	Basic 75 key keyboard, less electronics	*Consult Factory
Amplifier	Ten channel amplifier electronics for any of the above	\$100.00
Switches	Function switches in upper hood	\$ 30.00 each
Switches	Mounted at side of keyboard	*Consult Factory
Special Case	To incorporate special customer requirements	*Consult Factory

\* Prices shown are for standard keyboard layouts having diagonal key format only and standard cases. Special cases due to customer requirements or side mounted switches can be supplied, but require special pricing.

Normal discounts apply in lower quantity ranges, with production prices ranging down to the \$240 to \$270 range.